

Chillers 55000–70000 W

HK 55 WT / HK 62 WT / HK 70 WT

- stand-alone chiller, automatic operation
- fluid cooling with water, water/glycol mixtures, emulsions and low-viscosity oils*
- particularly suitable for outdoors and aggressive environmental conditions
- powder-coated steel housing
- cooling circuit controlled via a programmable temperature module
- anti-freeze thermostat
- transport eye bolts on housing
- integration of project-specific additional components is possible on request
- fluid cooling with oil on request



Further options for the HK series chillers can be found on page 124.

* maximum viscosity 10 cSt (10 mm²/s) @ + 40 °C

Data		HK 55 WT	HK 62 WT	HK 70 WT	Unit
Article number		42105500002	42106200001	42107000001	
Rated voltage ± 10 %		AC 50 Hz / 60 Hz			
		400 / 460 3~			V
Cooling capacity (with pump) ¹	W18/L32	55.0 / 72.5	62.0 / 72.5	70.0 / 89.0	kW
	W10/L32	42.5 / 51.5	49.5 / 58.0	53.0 / 63.0	
Flow rate (pump) ²		85	160	160	l/min
Pressure (head) (pump)		3			bar
Ambient temperature range		+ 15 ... + 40 / + 59 ... + 104			
Control range (refrigerant outlet temperature)		+ 10 ... + 35 / + 50 ... + 95; factory setting + 18 / + 64			°C/°F
Target value tolerance		± 2			K
Refrigerant	R407C	14500	16000	19000	g
Power consumption	W18/L32	19.7 / 25.9	23.8 / 28.0	28.5 / 33.3	kW
Current consumption	W18/L32	37.4 / 46.5	40.5 / 50.4	48.8 / 56.7	A
Starting current	W18/L32	220.8 / 266.8	232.6 / 267.5	311.7 / 334.6	A
Control voltage		24 V AC			V
Pre fuse T		on request			A
Volumetric airflow	external	14100 / 15510			m ³ /h
Tank volume		300			l
Connections (medium)	IG	1 1/2"			BSPP
Noise level according to EN ISO 3741		< 73			dB (A)
Weight (without packaging)		1081	1210	1315	kg
System of protection (enclosure electrical components)		IP 56			
Colour		RAL 7035, different colours available on request			
Accessories		Article number			
Overflow valve (internal)		48000012877	48000012884		
Differential thermostat + 2 m sensor		48000012878	48000012885		
Aluminium pre-filter (condenser)		45000012291			
20% Propyleneglycol pre-mix	20 l	45783000123			
20% Ethyleneglycol pre-mix	20 l	45783000125			
Automatic water refilling		on request			

¹ cooling capacity incl. power loss in the pump, refrigerant outlet temperature + 18 °C, ambient temperature + 32 °C

² performance data based on 50 Hz operation

Approvals see page 99

Cooling capacity performance curves

HK 55 WT (50 Hz)¹

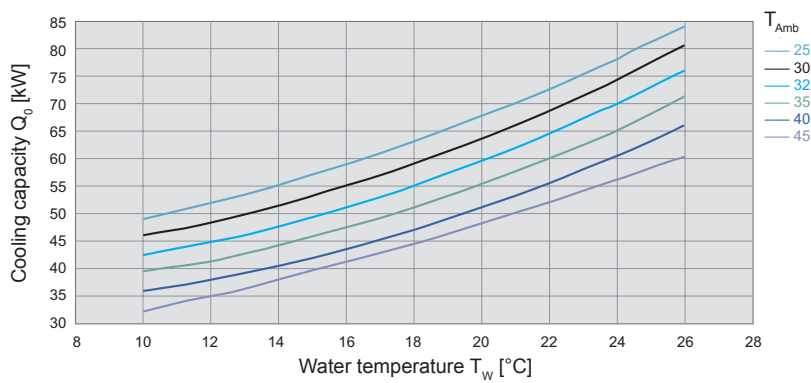

HK 62 WT (50 Hz)¹

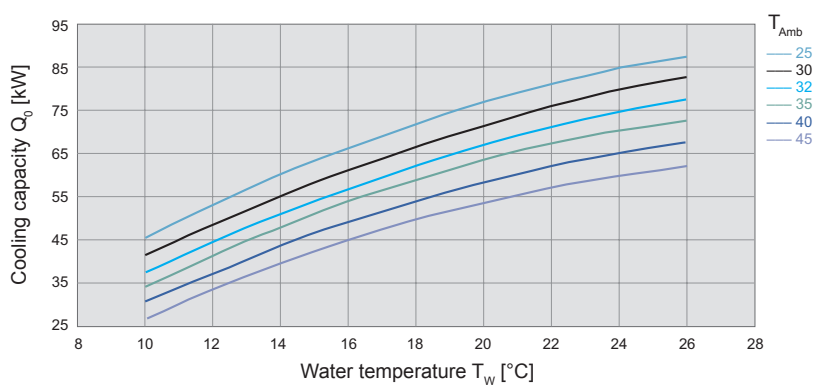

HK 70 WT (50 Hz)¹

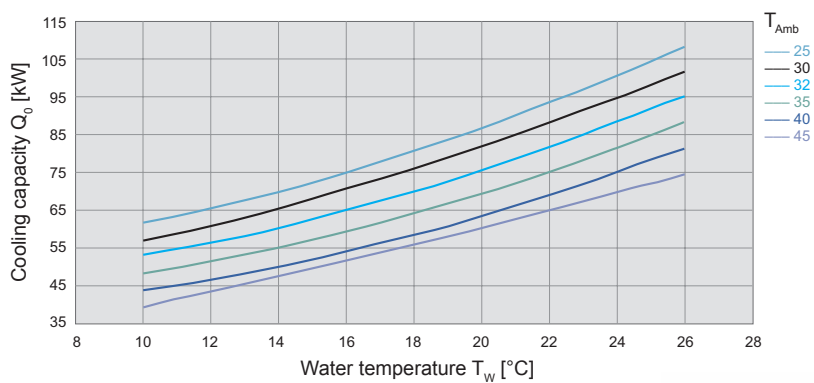

Dimensions

mm	HK 55/62/70 WT
X	2500
Y	1800 ²
Z	1110
A	2295
B	900

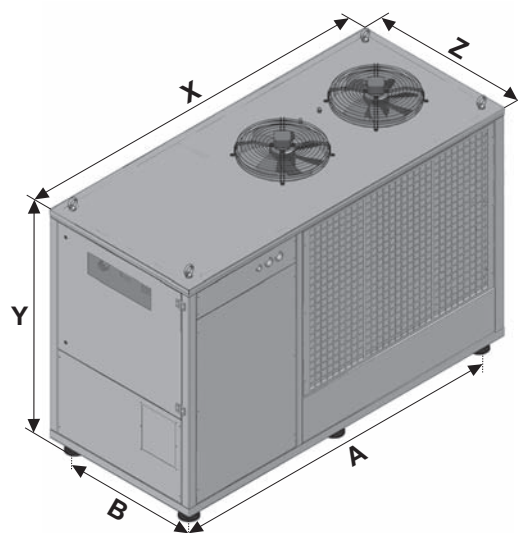

¹ the performance curves for the 60 Hz version can be obtained from your Pfannenberg advisor or at www.pfannenberg.com

² incl. fan